



Installation Manual

INDEX

1. *Product Description/Part Listing*
 2. *Handling of Materials*
 3. *Power*
 4. *Fitting the Ribbon to the Ribbon Mounts*
 5. *Connecting Ribbon lengths*
 6. *Fix Ribbons into place*
 7. *Mount the Power Supply*
 8. *Connect power to Ribbon*
 9. *Final Check*
 10. *APPENDIX A – Electrical Specifications*
-

PLEASE CAREFULLY READ & UNDERSTAND ALL INSTRUCTIONS IN THIS GUIDE.

All rights reserved. No part of this publication may be reproduced, stored in a retrieval system, or transmitted in any form or by any means, electronic, mechanical, photocopying, recording or otherwise, without the prior written permission of Associated Controls Pty Ltd. Neither is any liability assumed for damages resulting from the use of the information contained herein.

Associated Controls Pty Ltd have produced this manual as comprehensively and factually as possible. However, from time to time some of the information may be changed or updated. We reserve the right to make changes at anytime without notice.

This class of equipment is often installed in public areas. Hence, it is extremely important that all relevant safety codes and standards are followed when installing this product. Associated Controls Pty Ltd shall not be liable to the purchaser of this product or third parties for damages, losses, costs or expenses incurred by the purchaser or third parties as a result of failure to comply with Associated Controls Pty Ltd installation, operating & maintenance instructions.

Diolight is a registered trademark of Associated Controls Pty Ltd.

Note: Other product names used herein are for identification purposes only and may be trademarks of their respective owners. Associated Controls Pty Ltd disclaims any and all rights in those marks.

Copyright © 2002 by Associated Controls Pty Ltd, Sydney, Australia.



2-4 Norfolk Road, Greenacre
Ph: (02) 9642 4922, Fax: (02) 96424955

1. Product Description/Part Listing

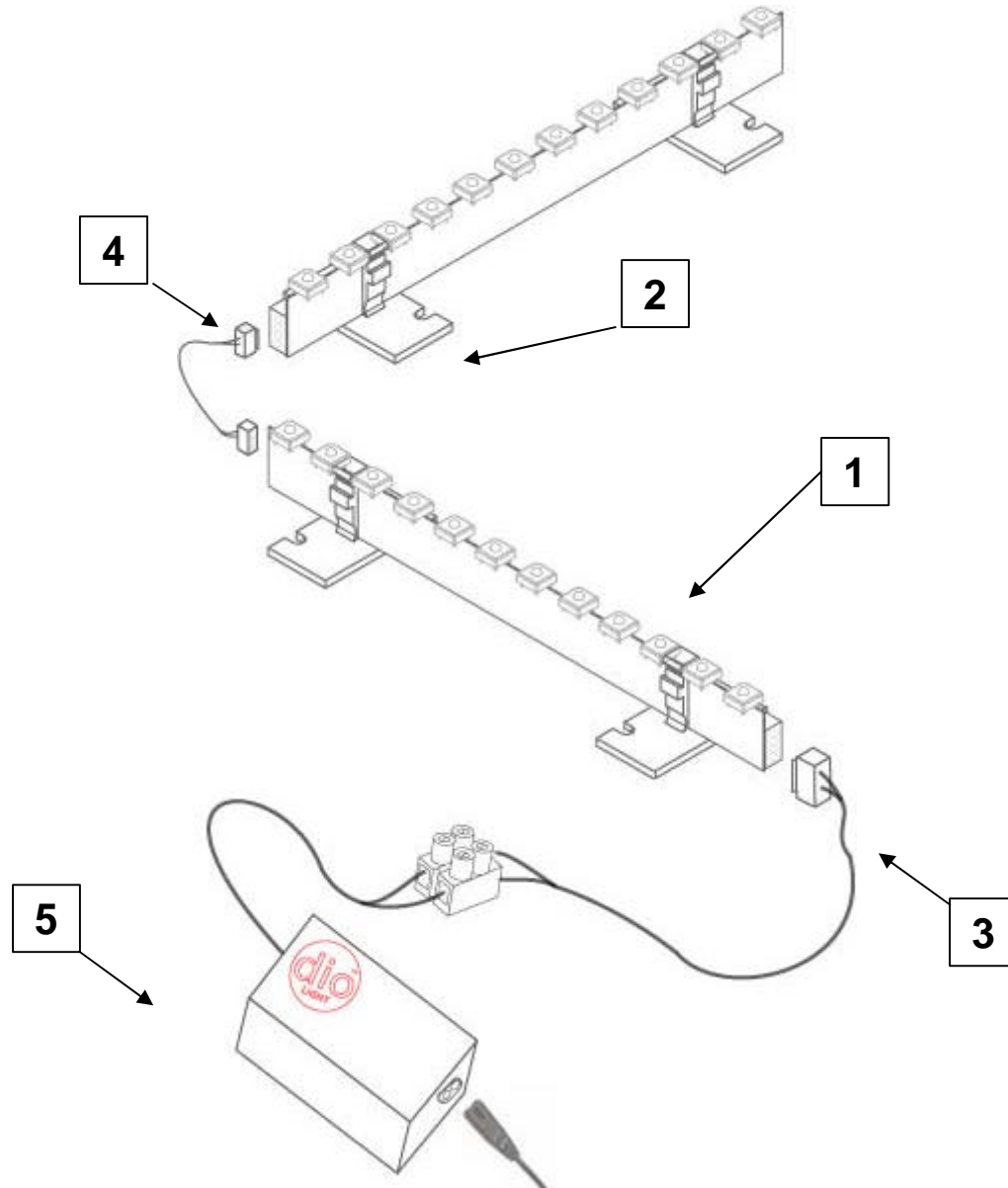

ITEM NO.	PART NUMBER	DESCRIPTION
1		DIO™ Ribbon (available in 540mm, 180mm & 30mm lengths and a selection of colours)
2	1171003	DIO™ Ribbon Mount (Static)
3	1175001	DIO™ Ribbon Input Cable
4	1175003	DIO™ Ribbon Linking Cable
5	2002100	DIO™ 12V DC Switchmode Power Supply (includes IEC Plug)

2. Handling of Materials

? **HANDLE ALL ELECTRONIC COMPONENTS WITH CARE.**



2-4 Norfolk Road, Greenacre
Ph: (02) 9642 4922, Fax: (02) 96424955

- ? **DO NOT BEND RIBBON REPEATEDLY AS THIS MAY DAMAGE COMPONENTS ON THE RIBBON.**
- ? **DO NOT BEND RIBBON AT RIGHT ANGLES AS THIS MAY DAMAGE COMPONENTS ON THE RIBBON.**

3. *Power*

- ✍ **DO NOT TURN POWER SUPPLY ON UNTIL LOAD IS CONNECTED.**
- ✍ All power outlets to be Residual Current Device protected.
- ✍ Power outlet to be connected to switchboard in accordance with application requirements.
- ✍ Ensure GPO is connected to the correct circuit-breaker circuit before commencing.
- ✍ Exposed cable to be housed in conduit.
- ✍ Ensure cable is protected against damage.

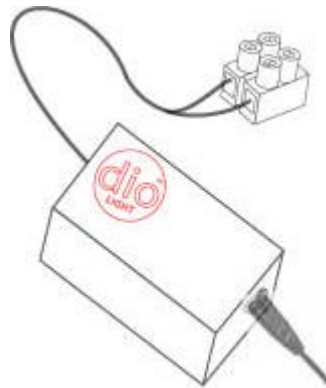

- ✍ Mount the power supply in a secure location.
- ✍ Ensure power supply vent slots are unobstructed.
- ✍ Ensure area is dry and not subject to liquid spills/splashes.
- ✍ Check mains power cable is secured as necessary to ensure safe, ongoing use.

Fitting the Ribbon to Ribbon Mounts

- I. Slide the Ribbon into the open Ribbon Mount. The Ribbon Mount should rest between the DIO's & be located to provide greatest stability.
- II. Once in place close the clip to secure it to the Ribbon.
- III. To adjust the placement of the clip, lever the clip open with a screwdriver.

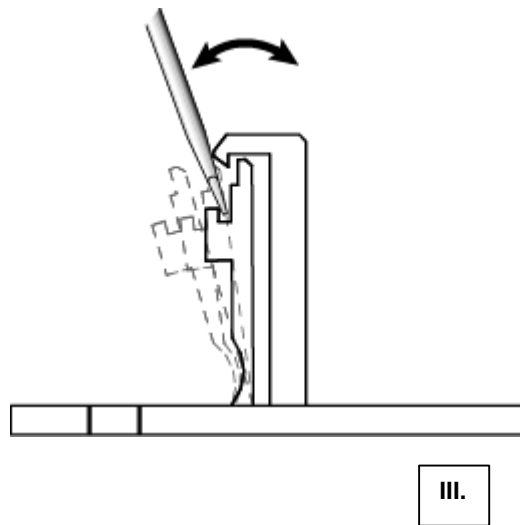
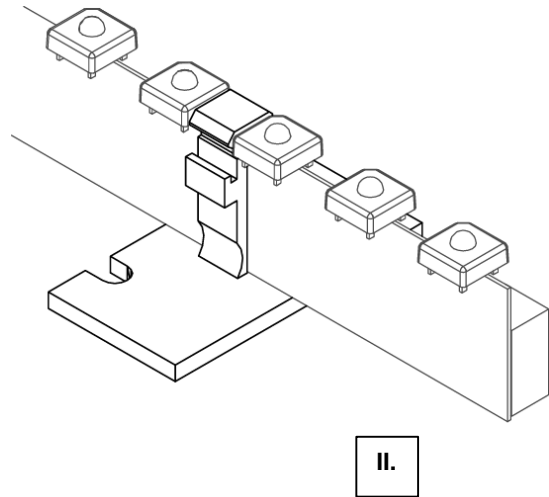
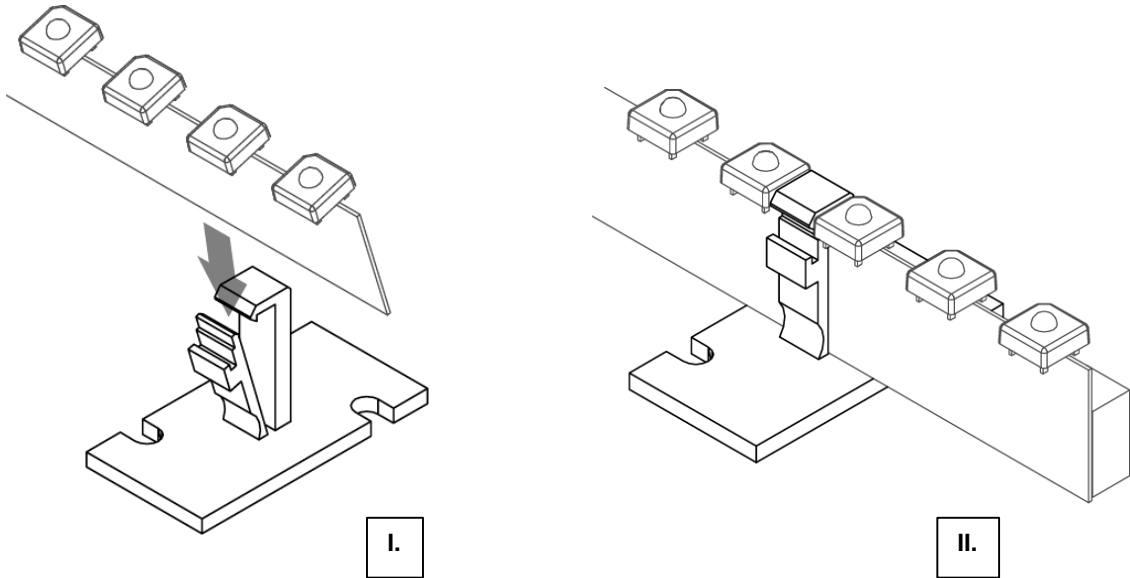

5. Connecting Ribbon lengths

- ✎ Connect the DIO Ribbon sections together (with Ribbon Mounts attached) to complete *the maximum run length as specified in Appendix A (page 7)*
- ✎ Use linking cables in situations where sections cannot be directly joined together.



To create continuous lengths,
click varying DIO Ribbon lengths together

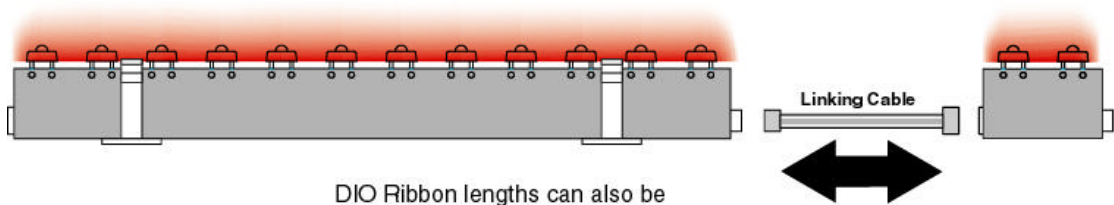

DIO Ribbon lengths can also be
linked using a linking cable

6. Fix Ribbons into place

- ✎ Fix all Ribbons into place by mechanically fixing the Ribbon Mounts to the mounting surface using screws or double-sided tape.

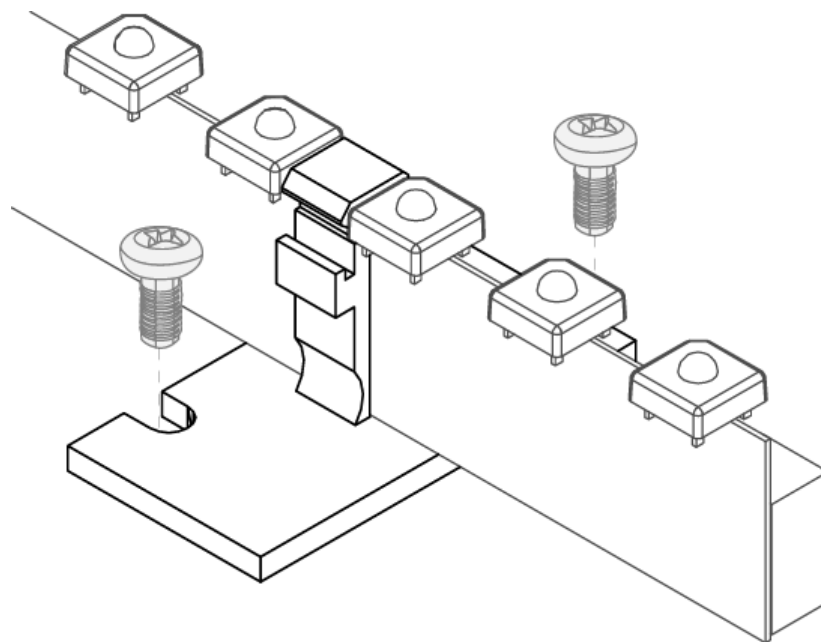

7. Mount the Power Supply

- ✍ Mount the Power Supply as close to the installation as possible.
- ✍ Ensure that the input cable comfortably reaches the start of the Ribbon run.
- ✍ Refer to Appendix A (page 7) to ensure that capacity of the power supply and maximum run lengths are not exceeded.

8. Connecting power to Ribbon

- ✍ Connect the Input Cable from the Power Supply to the start of the Ribbon run.

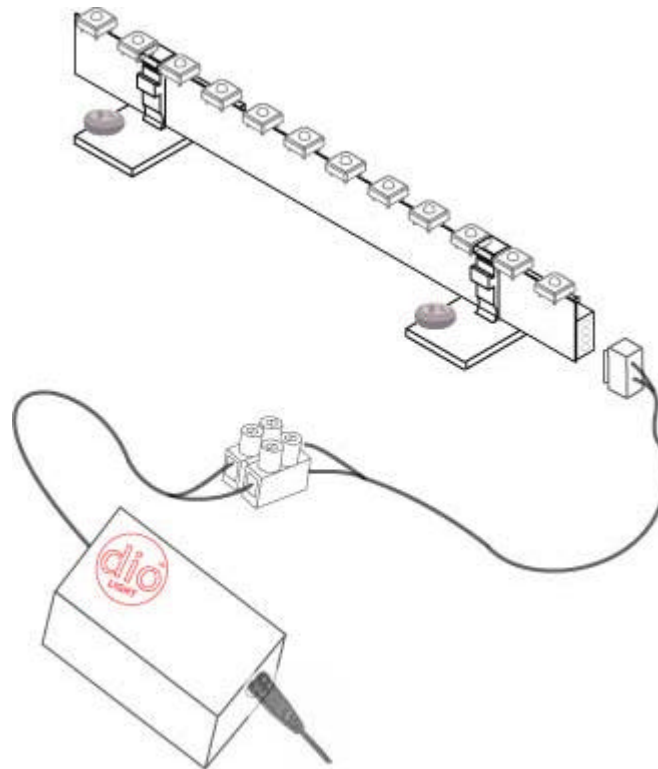

9. Final Check

- ✍ Check all connections between Power Supply & Ribbon.
- ✍ Check all connections between Ribbon sections.
- ✍ Ensure that Ribbon is securely fixed to mounting surface.
- ✍ Remove all dust & swarf from the area surrounding the Ribbon & Power Supply.

10. APPENDIX A – ELECTRICAL SPECIFICATIONS of DIO RIBBON

Parameter	Symbol	Static	Static	Units
		(Red/Amber)	(Blue/Grn/Cyan/White)	
<i>Operating Voltage (Typ)</i>	V_0	12	12	VDC
<i>Operating current per DIO™ (Typ)</i>	I_0	50	50	mA
<i>Max. Length of circuit (15mm pitch)</i>	L	5.4	5.4	Metres
<i>Total combined metres per Power Supply (80watt unit) (15mm pitch)</i>	L	7.4	7.4	Metres
<i>Max. Length of circuit (30mm pitch)</i>	L	10.8	10.8	Metres
<i>Total combined metres per Power Supply (80watt unit) (30mm pitch)</i>	L	12.8	12.8	Metres
<i>Max. Length of cable (24AWG) when fully loaded</i>	L	1.5	1.5	M



™